

MindPX

Autopilot System



Specification

V1.1

AirMind

Catalog

Summary	1
Specification.....	2
1. Hardware	3
MCU	3
Sensors.....	3
Communication.....	3
Power	3
Extension	3
2. Interface	5
1) PIN	5
2) Looper	6
3) Schematics.....	7
UART1 port	7
UART1 schematic.....	7
I2C port	7
I2C schematic.....	8
CAN port	8
CAN schematic.....	8
SPI port	9
SPI schematic	9
POWER port.....	10
POWER schematic.....	10
ADC port.....	11
ADC schematic	11
UART4/5 port.....	11
UART4/5 schematic.....	12
GPS PIN	12
GPS schematic.....	12
3. Support Vehicle & Configurition	13
4. Flight Mode	13
5. Compatibility	13
6. Open Source	14

Summary

MindPX is a new generation autopilot system branched from Pixhawk, been revised in schematic and structure, and been further enhanced with new features to make un-manned vehicle more smart and more friendly to use.

Equipped with the most powerful processor in class of industry, MindPX out stands other similar systems by strong performance, highly reliable flight control, comprehensive set of functions, and great expandability.

With ingenious internal design, MindPX is an extremely optimized system with lower total cost while has no trade off on performance.

As the platform designed for next generation smart un-manned vehicle, MindPX has following exciting new features:

- off-board access
- stackable assembly mode
- support new type of sensors like distance sensors, optical flow
- support new type of remote controller including smart phone, etc
- support auto take-off & landing
- support data fusion from multiple sensor sources

Specification

Dimension (mm)		61×48.2×16.5			
Weight (g)		45g			
Case material		Aluminium Alloy			
Case color		Silver			
Processor		STM32F427			
Sensors	Magnetometer	LSM303D	Rated Voltage		DC 5.0±0.5 v
			Output		PWM
	Accelerometer	MPU6500 & LSM303D	Temp (°C)	Stock Temp	15~35
				Working Temp	-10~85
	Gyro	L3GD20H & MPU6500	Humidity (RH)	Stock Humidity	30%~40%
				Working Humidity	10%~90%
Barometer	MS5611	Vibration Dampening		Built-in Vibration Dampen	

1. Hardware

MCU

- 32bit, STM32F427, Cortex M4 with FPU
- 168 MHz
- 1256 KB RAM
- 2 MB Flash

Sensors

- ST Micro L3GD20H 16 bit gyroscope
- ST Micro LSM303D 14 bit accelerometer/magnetometer
- MEAS MS5611 barometer
- InvenSense MPU6500 integrated 6-axis sensors

Communication

Full set of interfaces with no compromise:

- 5x UART(UART), 1 high-power capable, 2x with W flow control
- CAN x 1
- PPM sum signal
- I2C x 2
- SPI
- 6.6/3.3V ADC inputs
- microUSB1 (Ground Station)
- microUSB2 (External Controller)

Power

- All peripheral outputs over-current protected
- Input voltage: $5\pm 0.5V$

Extension

- External full color LED
- I2C splitter(normally not needed as MindPX already has 2 I2C ports)
- MindFLOW
- USB2 port for development and external control

- GPS port

2. Interface

1) PIN

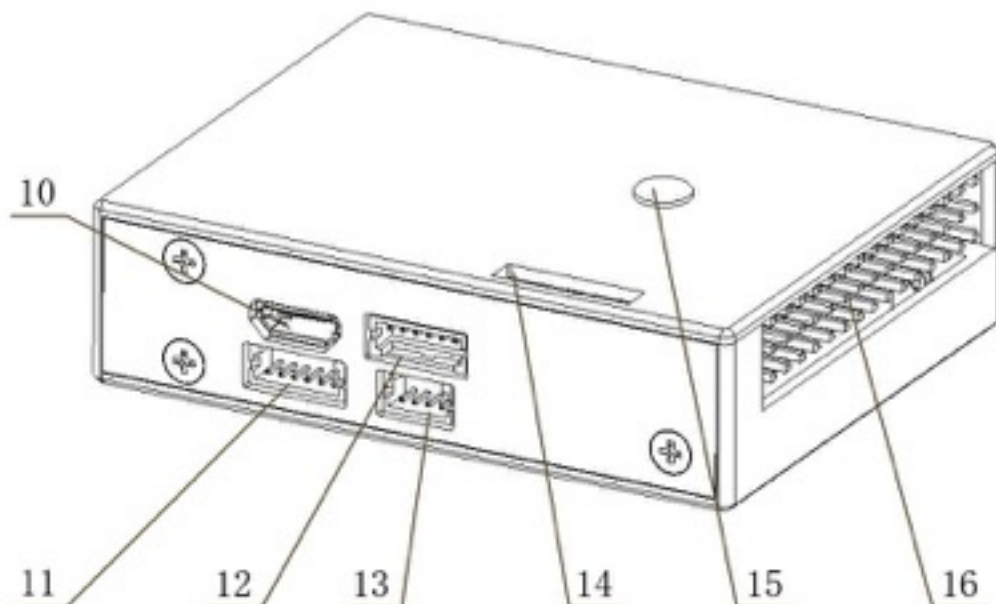
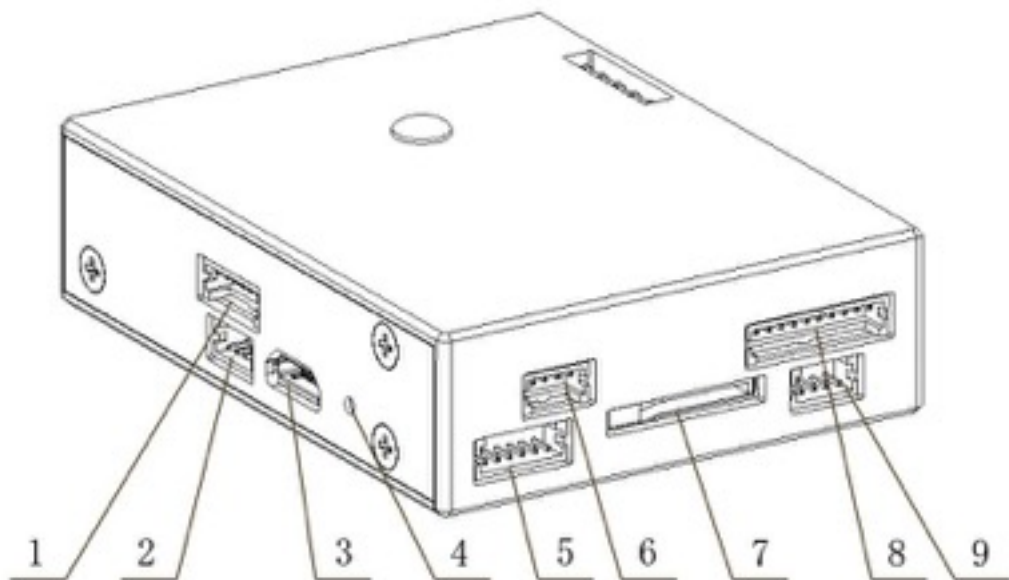

- | | |
|-------------------------------|-------------------------|
| 1. Power | 9. I2C2 (MindFlow) |
| 2. Debug (refresh bootloader) | 10. USB2 (Serial 2 to) |
| 3. USB1 (refresh firmware) | 11. UART4,5 |
| 4. Reset | 12. UART1 (Telemetry) |
| 5. UART3 (GPS) | 13. CAN |
| 6. I2C1(external compass) | 14. ADC |
| 7. TF card slot | 15. Tricolor LED |
| 8. NRF/SPI(Remote Control) | 16. Looper |

2) Looper

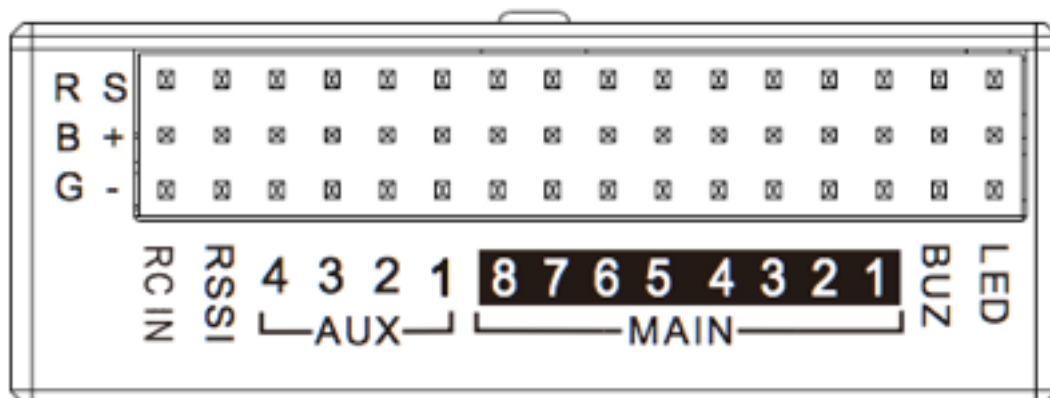

3) Schematics

UART1 port

Pin	1	2	3	4	5	6
Signal	+5V	TXD	RXD	CTS	RTS	GND
Volt	+5V	+3.3V	+3.3V	+3.3V	+3.3V	GND

UART1 schematic

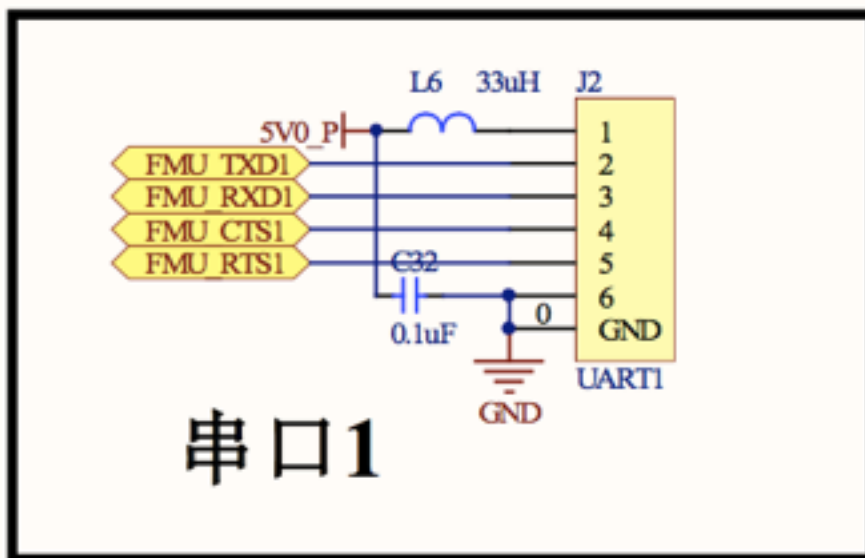

I2C port

Pin	1	2	3	4
Signal	VCC	SCL	SDA	GND
Volt	+5V	+3.3V	+3.3V	GND

I2C schematic

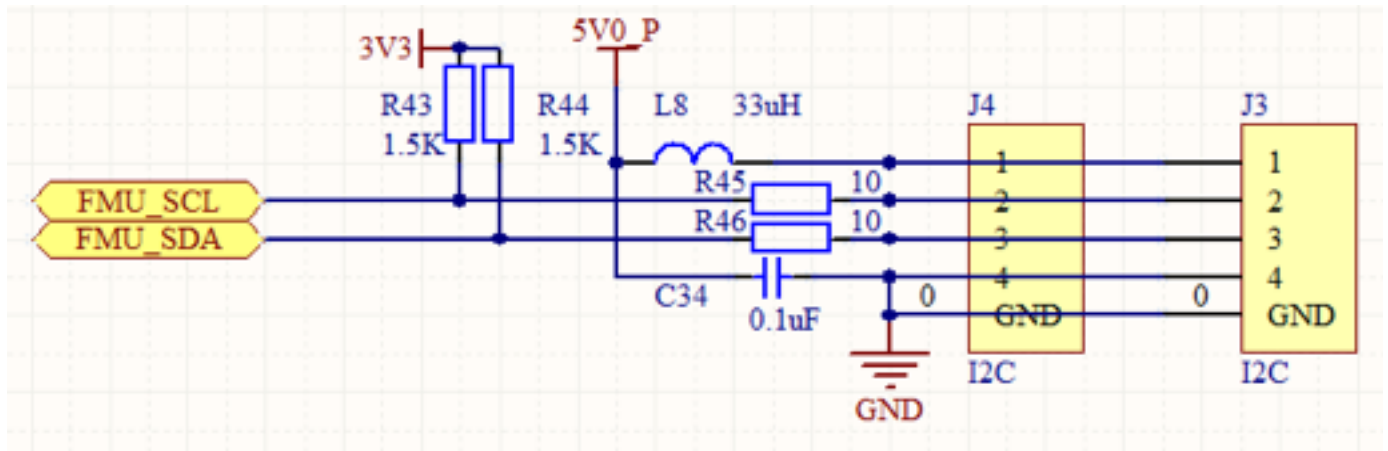

CAN port

Pin	1	2	3	4
Signal	VCC	CAN_H	CAN_L	GND
Volt	+5V	+12V	+12V	GND

CAN schematic

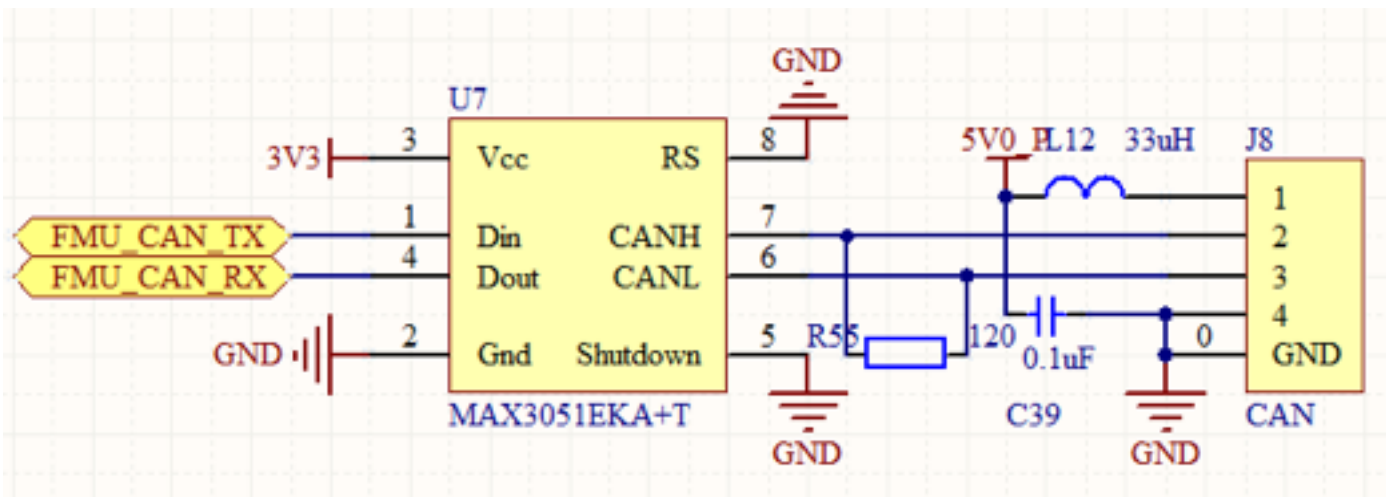

SPI port

Pin	1	2	3	4	5
Signal	VCC	N/A	N/A	NRF_CS	NRF_CSN
Volt	+5V			+3.3V	+3.3V

Pin	6	7	8	9	10
Signal	FMU_S PI_SCK	FMU_SPI_- MOSI	FMU_SPI_MISO	NRF_INT	GND
Volt	+3.3V	+3.3V	+3.3V	+3.3V	GND

SPI schematic

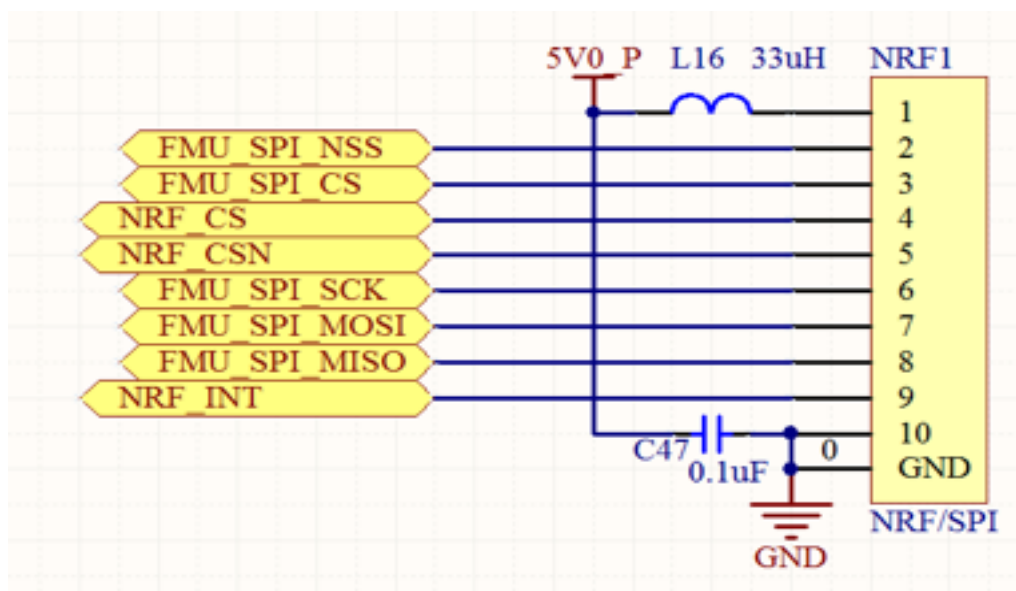

(Shared by NRF2.4G remote communication module and external SPI)

POWER port

Pin	1	2	3	4	5	6
Signal	VCC	VCC	CURRENT	VOLTAGE	GND	GND
Volt	+5V	+5V	+3.3V	+3.3V	GND	GND

POWER schematic

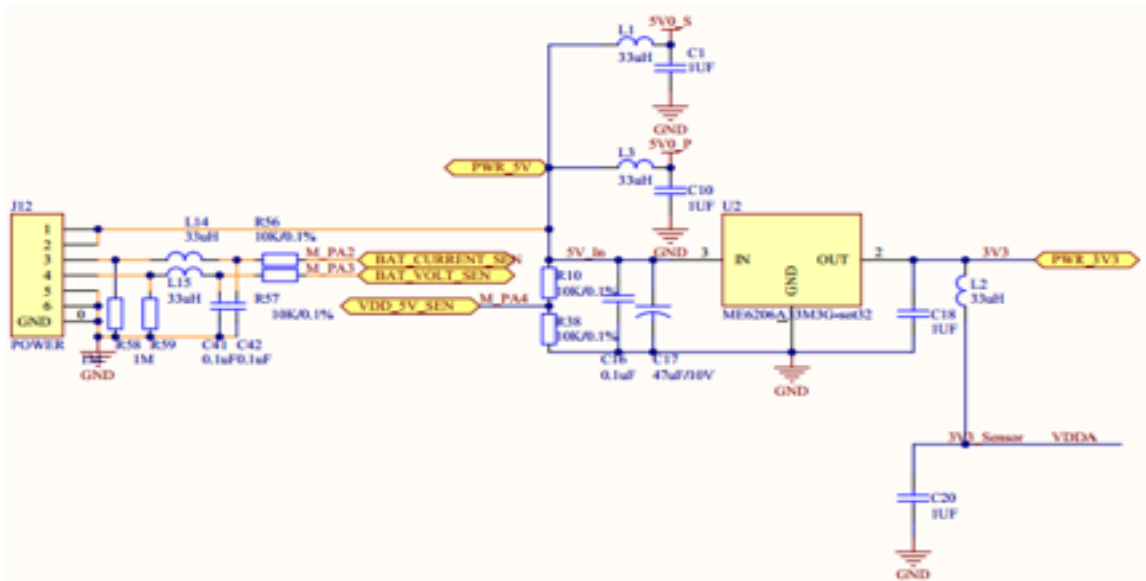

ADC port

Pin	1	2	3	4	5
Signal	VCC	FMU_ADC3 (Pressure)	FMU_ADC2	FMU_ADC1	GND
Volt	+5V	Up to +6.6v	Up to +3.3v	Up to +3.3v	GND

ADC schematic

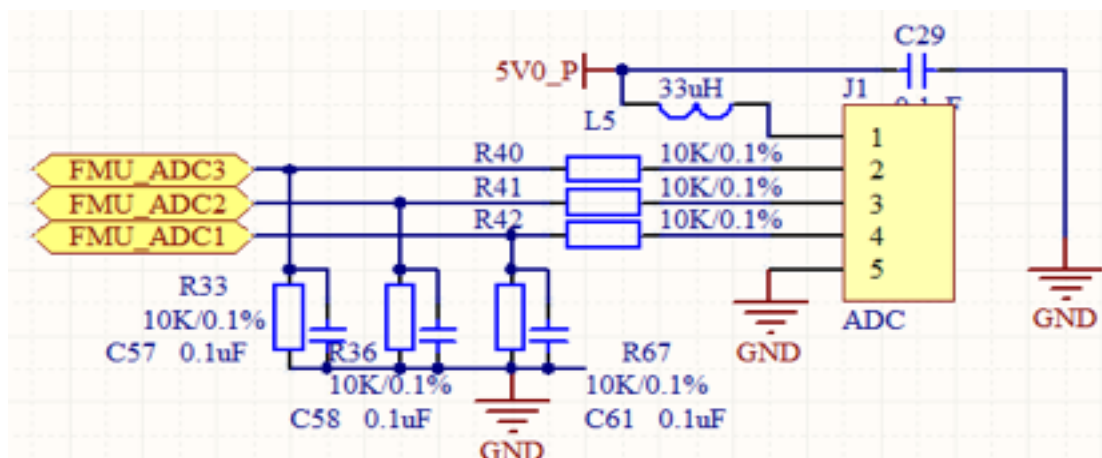

UART4/5 port

Due to space constraints two ports are on one connector.

Pin	1	2	3	4	5	6
Signal	VCC	FMU_TXD4	FMU_RXD4	FMU_TXD5	FMU_RXD5	GND
Volt	+5V	+3.3v	+3.3v	+3.3v	+3.3v	GND

UART4/5 schematic

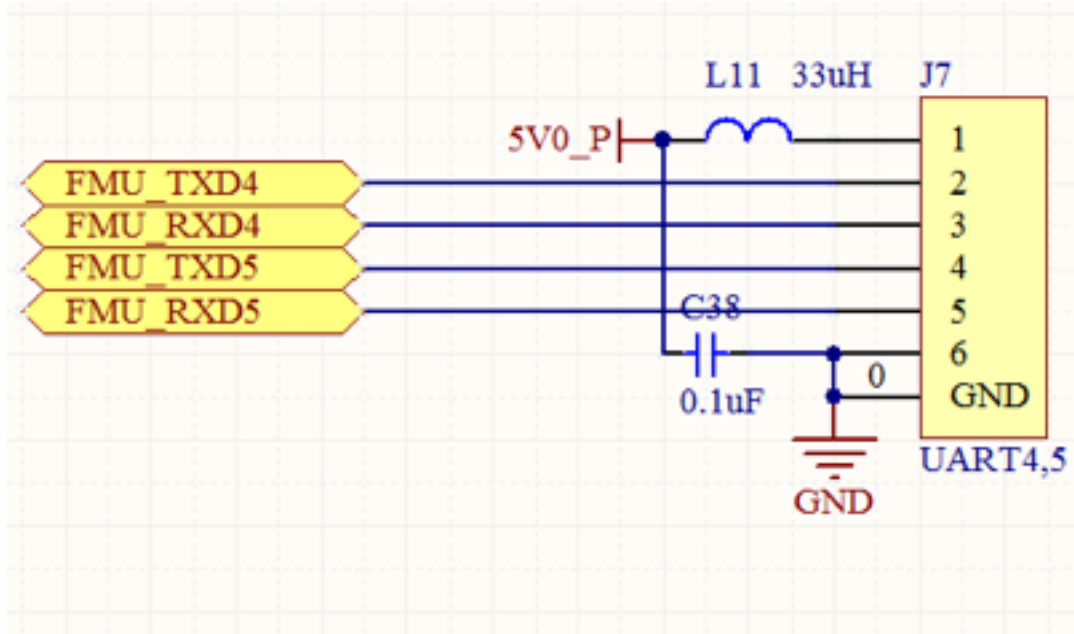

GPS PIN

Pin	1	2	3	4	5	6
Signal	VCC	FMU_TXD3	FMU_RXD3	N/A	N/A	GND
Volt	+5V	+3.3v	+3.3v			GND

GPS schematic

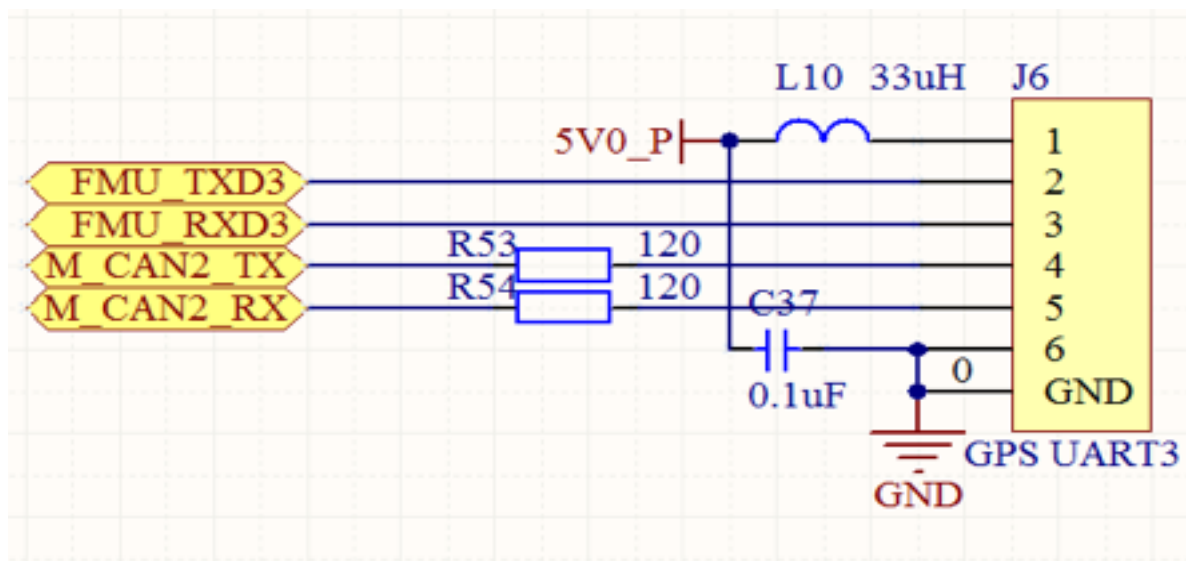

3. Support Vehicle & Configuration

MindPX supports a variety of air frames:

dual-rotor, tri-rotor, 4x, 4+, 6x, 6+, 6Y, 8x, 8+, Y6, X8, X16

4. Flight Mode

1) **Manual mode** Control drone flight manually

2) **Assist mode**

Altitude control: Hold altitude during the flight

Position control: Hold position during the flight

3) **Auto mode**

One-click taking off: Take off and fly to specific altitude by using MindPX app

One-click landing: Easily land by using MindPX app

Navigation mode: Set waypoints or air line to make drones fly automatically

RTL: Easily return back to launch

5. Compatibility

MindPX hardware is compatible with PX4 flight stack. You can download compatible PX4 flight stack from:

<https://github.com/airmind/OpenMindPX>

6. Open Source

MindPX is an entirely open source pilot system which include both hardware and software. You can download schematics and PCB layout from here :

<https://github.com/airmind/Hardware>

Software code is available here:

<https://github.com/airmind/OpenMindPX>

MindPX hardware follows CC BY-SA3.0 open source license agreement, Mind-PX software follows GPLv3 open source license agreement.